



SHEAR CONNECTORS

ACC. TO DIN EN ISO 13918



PRODUCTION ON MODERN MULTI-STAGE PRESSES ENSURES HIGH QUALITY AT LOW COST.

DESIGN SOFTWARE FOR STEEL MOUNTING HARDWARE WITH WELDED-ON SB SHEAR CONNECTORS

Free download: sddesignpro.bolte.gmbh

DIMENSIONS (mm)

d_1	l_2	d_5	k
10	50-200	19	7,1
13	50-400	25	8
16	50-525	32	8
19	75-525	32	10
22	75-525	35	10
25	75-525	41	12

Not listed dimensions available upon request

MATERIALS

S235J2+C470, 1.4301

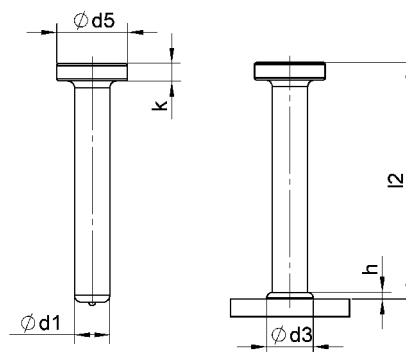

before welding / after welding



CE-CONFORM

SB shear connectors are CE-conform. They fulfill all essential requirements of the Construction Products Regulation (Regulation (EC) No. 305/2011/EU).



EUROPEAN TECHNICAL ASSESSMENT ETA-11/0120

The European Technical Assessment ETA-11/0120 of the European Organisation for Technical Approvals (EOTA) issued by the German Institute of Civil Engineering (DIBt) is on hand.



MADE IN GERMANY

SB shear connectors are made in Germany at our location in Gevelsberg (certified according to DIN EN ISO 9001).





Bolte GmbH

Flurstraße 25
D-58285 Gevelsberg

Tel.: +49 (0)2332 55106-0
Fax: +49 (0)2332 55106-11

Ohmstraße 3
D-85221 Dachau

Tel.: +49 (0)8131 5159-0
Fax: +49 (0)8131 5159-11

E-Mail: info@bolte.gmbh



www.bolte.gmbh